

RETROFIT

INCREASED

- Capacity
- Reliability
- Uptime

BETTER

- Performance
- Bucket design
- Product filling

LESS

- Spillage
- Service
- Cleaning
- Operational costs
- Dust formation
- Power consumption

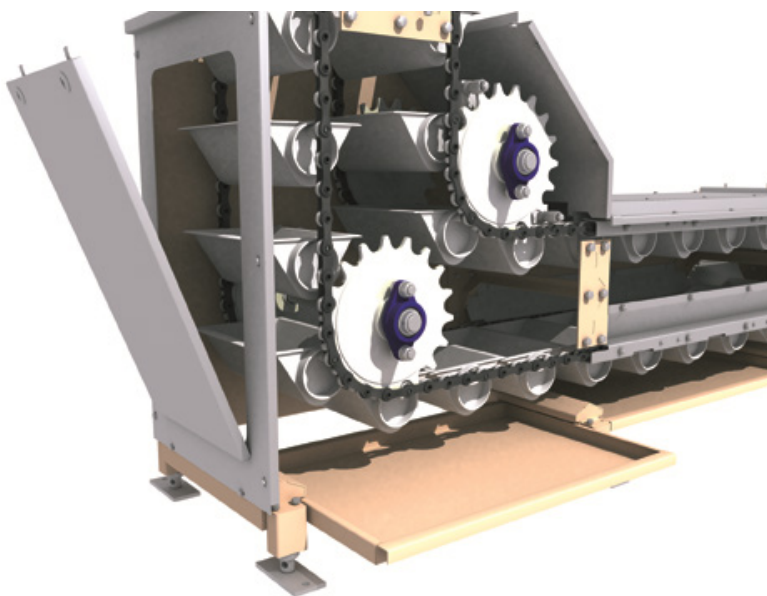

universal **ELEVATOR**



Upgrade of Existing Elevators

Cost efficient solution

Over the years Simatek Bulk Systems has been dedicated to continuously improve operational reliability, increase capacity and reduce service costs on the universal elevators.

If you want to be up to date with the latest technology in the conveying of bulk products, upgrading your existing elevator is a relatively inexpensive way to achieve this.

THE NEXT GENERATION elevator technology with its many advantages can successfully be implemented on existing elevators. An upgrade will ensure higher capacity, lower operational costs, lower power consumption, and also require less cleaning and fewer service checks.

Individual adjustments and considerations regarding physical restrictions must be taken and Simatek Bulk Systems offers technical support, supervision and complete installation when retrofitting an existing universal elevator.

Implementing a new product feeder

If your existing universal elevator is installed with a traditional feeding system it is possible to obtain significant advantages when replacing it with a Simatek Drum Feeder.

The Simatek Drum Feeder is the newest technology within gentle feeding of Simatek Universal Elevators. This unique, mechanical drum feeder has many advantages compared to traditional feeding systems.

The drum feeder is synchronised with, and mechanically driven by the elevator chains. This enables precise product filling at any conveying speed.

- **Adjustable & high filling degree**
- **Gentle feeding**
- **Cleaning-friendly design**
- **Robust design**
- **Potential use of FRB buckets**
- **No product spillage**
- **PLC or analog capacity regulation**
- **Preset up to 7 product recipes**

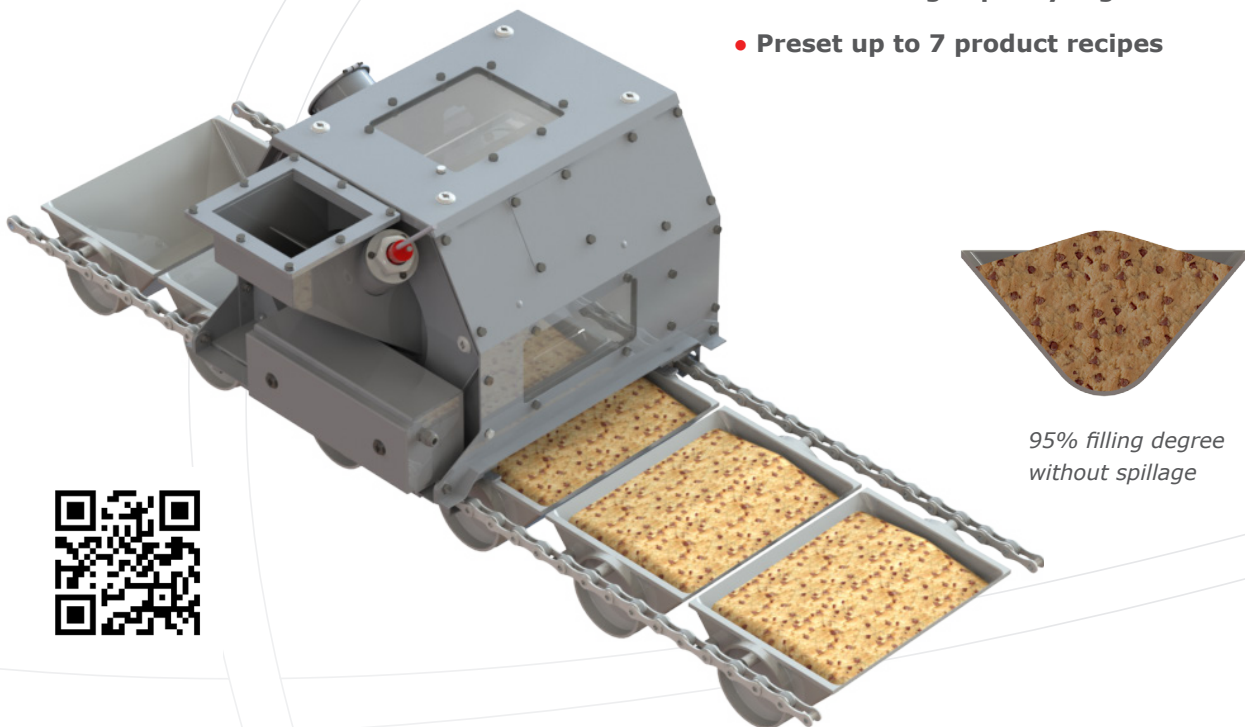

Free Rotating Buckets (FRB)

Contrary to the traditional bucket designs there is no physical contact between the FRB buckets, which is why there is no need for wearable parts such as guides and forced controlling.

- **Less wear parts**
- **Greater reliability**
- **No sensitive elevator guides**
- **Less service**
- **Less wear**
- **Lower power consumption**

The FRB buckets are available in moulded polypropylene and in pressed stainless steel, depending on the elevator type.

Pressed buckets have service-friendly, replaceable gables in solid plastic.

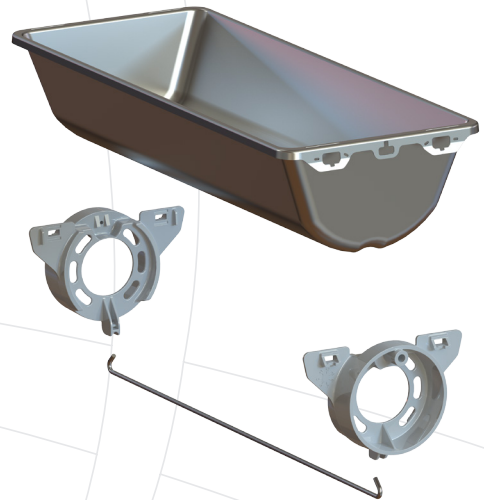

Same Elevator – higher capacity – up to 85%

The capacity for existing universal elevators may be increased significantly when replacing the standard buckets with FRB buckets, which have a higher volume.

If the traditional vibrating feeder is replaced with a Simatek Drum Feeder it will result in a remarkable capacity increase, even with the same chain speed.

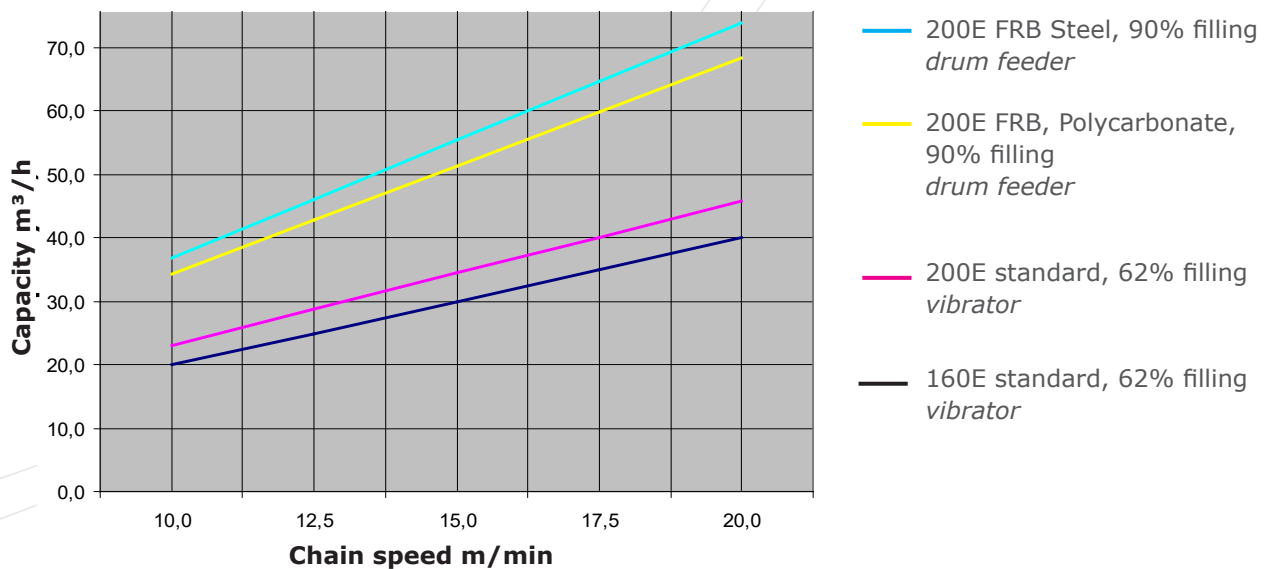

When retrofitting an existing universal elevator type 160-E to type 200-E with FRB steel buckets and a Simatek Drum Feeder, the capacity may be increased to reach up to 85%.

The same retrofit of a traditional elevator type 200-E will result in a capacity increase of approx. 60%. When retrofitting to a larger capacity, gears and shafts may have to be changed.

A Gentle and Flexible Solution

Bearing suspension for FRB buckets

- Ideal for abrasive products
- Less wear
- Lower power consumption

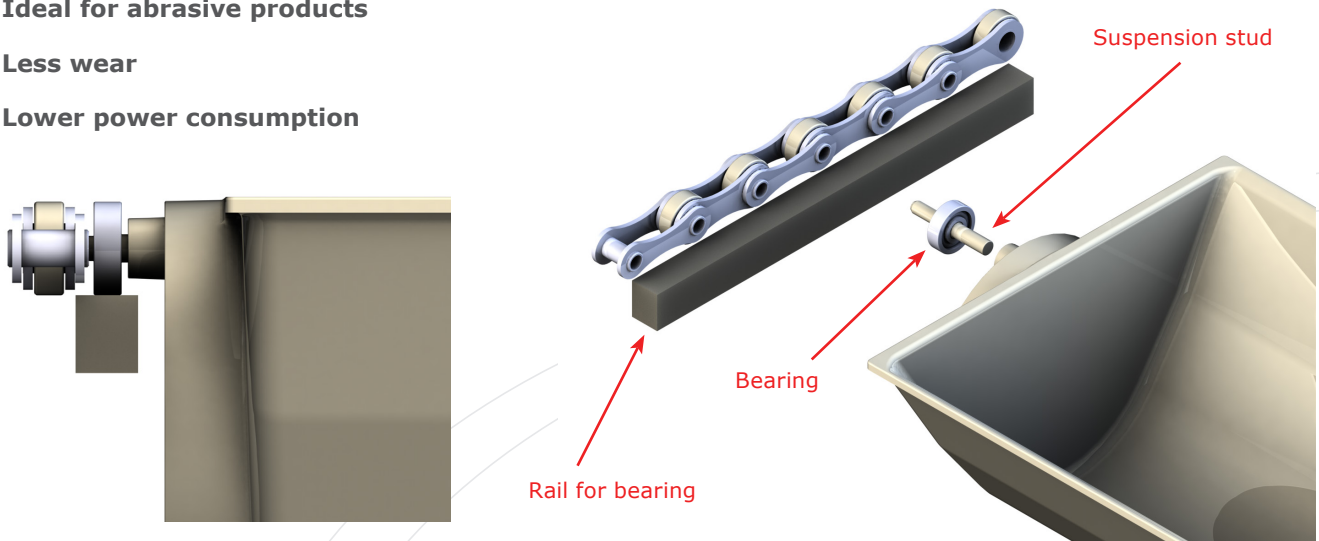

For very abrasive products and/or long horizontal conveyance the chains may last considerably longer if bearings between chains and FRB buckets are installed.

This will ensure reduced friction and less strain on the chain rolls and thereby result in a reduced power consumption - in some cases more than 70%.

Customer statements

In 2014 we upgraded a Simatek elevator from 1997 with a drum feeder. This has been a good investment both economically and practically.

The capacity has increased significantly. Our wear parts budget is at a minimum now. The elevator is much cleaner than before due to less spillage and no buckets have broken since the upgrade.

Another very important advantage is the fact that the elevator is now much more reliable and there is no operational stop anymore.

This is, of course, very cost efficient and I can honestly say, that all of these benefits have convinced us that when we are going to rebuild some of our other Simatek elevators, or purchase new ones, it will for sure be with FRB buckets and a drum feeder.

Carsten Lenz Pedersen
Maintenance Manager
Biomar, Denmark

At Ewos, Scotland we upgraded 3 of our Simatek elevators in 2016. We replaced our existing feeding systems with Simatek Drum Feeders. Also we replaced our traditional buckets with steel buckets without overlap. So far the results have been very positive.

Our capacity has been increased keeping the chain speed much the same as before. We have very little maintenance now and a no spillage. The fact that the elevator guides have been eliminated has been fantastic and there have been no issues since the upgrading of the elevators.

The operational costs have decreased as the wear more or less is eliminated.

Overall it is a good and much more reliable solution for us making it possible to keep the older elevators in use in our factory rather than replacing them with new ones.

Mark Wright
Regional Manufacturing Director
Ewos, Scotland